

Installation and Operation Guide

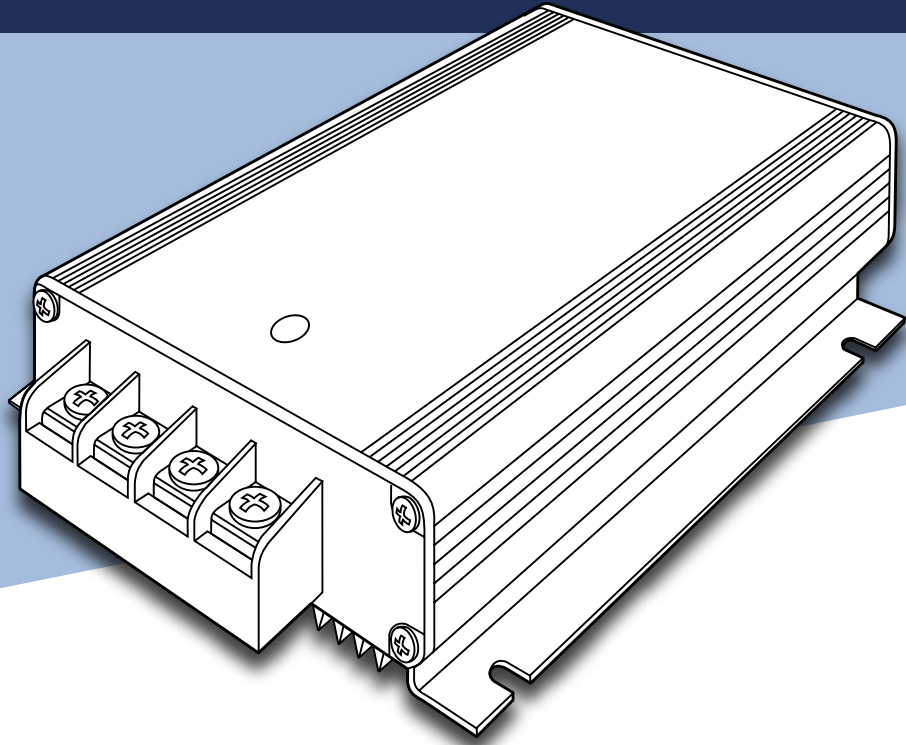

GENERAL

Intervolt SVC Series Switchmode Voltage Converters are designed for high demand power requirements in both vessel and vehicle applications. They are suitable for powering a large range of auxiliary 12 VDC equipment including communications, navigation, monitoring, instrumentation, lighting, refrigeration and much more.

Intervolt SVC's incorporate a range of innovative features including an industry first micro-processor controlled, multi-function diagnostic indicator. This feature is designed to help trouble-shoot general installation errors and assist in fault finding common problems.

Intervolt SVC's are fully protected from typical connection and installation faults by a range of built-in safety devices. These devices protect the units from reverse connection, short-circuiting, overloading, high output voltages and high temperatures. The case of the unit is ungrounded therefore ensuring electrical isolation.

Intervolt SVC's are designed to cope with the harsh demands of the marine environment. They are constructed of quality marine grade materials and when applied and installed correctly are designed to provide many years of continuous service.

Intervolt SVC's are manufactured in Australia and comply with both Australian and European Standards for Electro-Magnetic compatibility. They are supported by a 100% factory backed 24 month warranty against faulty components and/or workmanship.

INSTALLATION

The SVC must be properly mounted in order to comply with environmental considerations and the manufacturer's warranty terms and conditions. As the SVC is ungrounded it can be mounted directly to any metal surface and maintain electrical isolation.

1. Select a suitable location where the SVC can be mounted on a vertical surface (i.e. bulkhead, firewall, etc.) with the connection end facing downward .
2. Ensure SVC is located in a well ventilated position, free from excessive moisture, dust, vibration and heat.
3. Fix the SVC with appropriate fasteners ensuring all anchor holes are utilised.
4. Disconnect the 24VDC supply at the source before attempting any connection to the SVC or auxiliary equipment.
5. Install an appropriately rated circuit breaker or fuse (see chart) as the input protection for the 24VDC supply cable to the SVC.
6. Connect all circuits to the SVC ensuring that adequate cable sizes are used for model installed (consult your cable supplier for correct current ratings).
7. Reconnect the 24VDC supply at the source. The LED Diagnostic Indicator on the SVC should now be flashing green intermittently. If there is no output supply refer to fault finding section at rear of booklet.

WIRING DIAGRAM

TYPICAL UNGROUNDED INSTALLATION

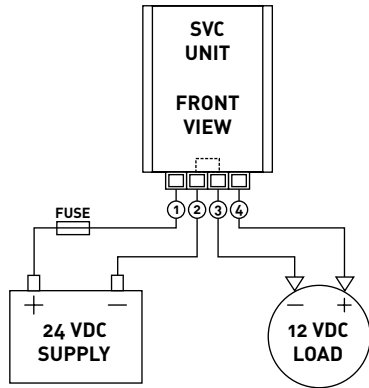

Input Fuse or Circuit Breaker Selection	
Model	Rating
SVC241215	15 Amp
SVC241220	20 Amp
SVC241230	25 Amp
SVC241240	30 Amp

①	24 VDC Positive Input
②	0 VDC Internally Linked as Common Negative
③	12 VDC Positive Output

See installation instructions on previous page for additional information regarding connection

TYPICAL GROUNDED INSTALLATION

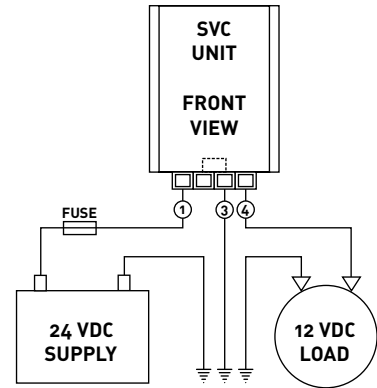

OPERATION

The SVC is designed to provide a constant supply at the rated current for 12VDC equipment. The SVC is protected from a variety of connection and application errors by a range of built in devices. In most instances these errors are revealed by the diagnostic indicator and can be corrected without having damaged the unit. The SVC is protected in the following situations:

- **Low Input Voltage** If the input voltage falls below 17VDC the SVC will be disabled. When the input voltage rises above this setting the output supply will be restored.*
- **High Temperature** In the event the SVC exceeds the preset temperature limit, the unit will be disabled. When the temperature decreases the output supply will be restored.*
- **Output Short Circuit** If the output supply is short circuited the SVC will be disabled. When the short is removed the output supply will be restored.*
- **Output Overload** If the maximum current rating is continuously exceeded the unit will be disabled. When the load is reduced the output supply will be restored.
- **Input Reverse Connection** If the input terminals are reverse connected the SVC will become inoperable. The input circuit is diode controlled and protected by an internal fuse which is not user serviceable.
- **Output Over Voltage** A Zener crowbar circuit prevents the output supply from high voltage. The circuit is protected by an internal fuse which is not user serviceable.
- **Transient Input Voltage** A purpose designed circuit filters out surges and spikes.

*Refer diagnostics and fault finding section on next page for trouble-shooting these problems.

WARRANTY

Intervolt products are warranted for a period of 24 months against faulty materials and/or workmanship from date of last sale or a maximum of 36 months from the date of manufacture subject to the following terms and conditions.

- The goods must be installed and operated in accordance with the manufacturers recommendations and instructions set out within this booklet.
- In the event of a claim the goods are returned to the original point of purchase with a copy of the merchant invoice or the relevant merchant invoice number.
- In the event of a claim any associated expenses including diagnosis, removal, and/or installation of the goods is the responsibility of the client including any freight costs.
- The warranty shall be void where the goods have been used for a purpose for which they are not intended, or altered in any way that is detrimental, or opened or tampered with by an unauthorised party, or damaged by mechanical abuse, or contaminated by water or other substances, or damaged by incorrect application.
- Save and except for the express warranty set out above and to the maximum extent permitted by law, all conditions and warranties which may at any time be implied by the common law, Trade Practices Act, Fair Trading Act or any other State or Federal Act are excluded. To the extent that these cannot be excluded and where the law permits, the manufacturer in respect of any such condition or warranty shall be limited at their option to the repair or the replacement of the goods or the supply of equivalent goods or refunding the cost of the goods.

interVOLT is a registered trademark of Amelec Australia Pty Ltd. Amelec Australia Pty Ltd is registered by the Australian Communications authority and authorised to use the 'C' Tick mark accordingly. Our user number is N1816.

DIAGNOSTICS AND FAULT FINDING

Indication	Status	Cause	Remedy
Pulsing Green	System Normal	N/A	N/A
Pulsing Amber	Over Temperature	Lack of Ventilation	Check and ensure ventilation to unit is adequate
		Continuously exceeding Maximum Load rating	Check loads to ensure they do not exceed rating of SVC
Pulsing Red	Short Circuit or Overload	Short Circuit on Output Load	Remove load and check for short circuit
		Continuously exceeding Maximum Load rating	Check loads to ensure they do not exceed rating of SVC
Pulsing alternately Green/Red	Low Input Voltage	Input Voltage has dropped below 17VDC	Check voltage of battery supply
No indication	Out of service	Internal fault	Return to authorised service centre