

interVOLT SVC Series fulfill the need for a high end 24VDC-12VDC voltage converter for arduous environments. Much emphasis has been placed on producing a voltage converter which delivers on the strength of our customer's requirements. Feedback indicated the need for above ground insulation, better termination, superior performance, heavy duty construction and above all, installer and user friendly. All design goals have been achieved, resulting in the development of a truly unique product for any application requiring a high specification.

## Performance Plus

Designed to deliver under harsh environmental conditions, these units can manage heavy, continuous loads in high ambient temperatures. Generous intermittent and peak ratings round off the performance package.

Input Voltage - 17-33V  
Output Voltage - 13.7V  
Continuous Load - 20A  
Intermittent Load - 25A  
Peak Load - 30A  
DESIGNED AND MANUFACTURED IN AUSTRALIA

## Designed to Endure

Only non-corrosive, marine grade materials are used in the manufacturing process. Featuring tropicalised circuitry for ultimate protection and longevity. Both robust by design and rugged in construction.



## About Conformity

Complies with Australian and European standards for Electro-Magnetic Compatibility (EMC), displaying both the 'C Tick' and 'CE' marks. Supported by independent examination from a certified testing house.



## Self Diagnosing

An industry first featuring dedicated fault finding circuitry. The Diagnostic Indicator assists in troubleshooting many common installation and application problems. A high brightness LED ensures greater visibility.

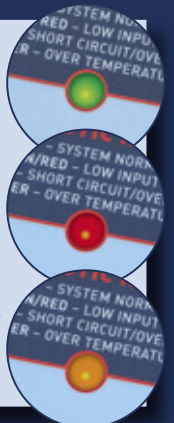

**interVOLT**  
www.intervolt.com  
**20 AMP**  
**24-12 VDC**  
**Switchmode**  
**Voltage Converter**

MODEL: SVC241220

Input Voltage - 17-33V  
Output Voltage - 13.7V  
Continuous Load - 20A  
Intermittent Load - 25A  
Peak Load - 30A

DESIGNED AND MANUFACTURED IN AUSTRALIA



## DIAGNOSTIC INDICATOR

GREEN - SYSTEM NORMAL  
GREEN/RED - LOW INPUT VOLTS  
RED - SHORT CIRCUIT/OVERLOAD  
AMBER - OVER TEMPERATURE

INPUT: 24V 0V OUTPUT: 0V 12V

## Safety First

For peace-of-mind, a range of dedicated devices protect both product and the equipment connected to it. Reverse connection, short circuit, output overload, voltage surges, spikes and transients - it's all covered.



## Australian Made

interVOLT products are proudly designed, engineered and manufactured in Australia. All products are 100% tested prior to packaging and despatch. The quality is backed by our solid two year guarantee (conditions apply).

## Feature Packed

Innovative design featuring superior termination, microprocessor control and advanced heat-sinking properties combine to produce a truly unique product in an attractive package.

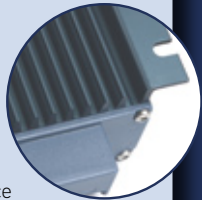

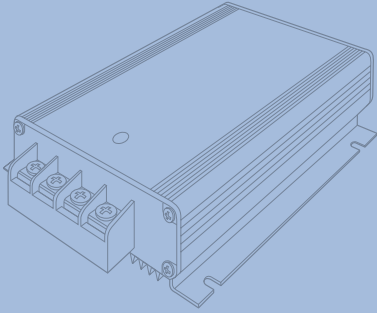

SVC241215



SVC241220



SVC241230



SVC241240

Continuous Load Rating @ 25°C	15 Amps	20 Amps	30 Amps	40 Amps
Intermittent Load Rating @ 25°C *	20 Amps	25 Amps	35 Amps	45 Amps
Peak Load Rating @ 25°C **	25 Amps	30 Amps	40 Amps	50 Amps
Length Overall	160mm	205mm	235mm	275mm
Width Overall	136mm	136mm	136mm	136mm
Height Overall	55mm	55mm	55mm	55mm
Weight	825 grams	1040 grams	1240 grams	1505 grams
Input Voltage Range	17-33 VDC			
Output Voltage	13.7 VDC nominal (up to the maximum rated load)			
Standby Current Draw	25 mA nominal			
Power Conversion Efficiency @ 25°C	Typically 93%			
Output Ripple	Less than 20 mV Peak to Peak			
Operating Temperature	Ideally -25°C to + 40°C			
Operating Humidity	Ideally less than 90%			
Enclosure Material	Marine grade aluminium dye anodised			
Enclosure End Caps	Injection moulded electrical grade ABS/PC plastic			
Diagnostic Indicator	Tri-colour LED - monitoring input voltage, overload, short circuit and temperature.			
Transient Voltage Protection	Filtering - Purpose designed circuit			
Over Load/Short Circuit Protection	Shutdown - Current sensing circuit (automatic reset)			
Input Under Voltage Protection	Shutdown - Voltage sensing circuit (automatic reset)			
Over Temperature Protection	Shutdown - Temperature sensing circuit (automatic reset)			
Negative Disconnect Protection	Shutdown - Voltage sensing circuit (automatic reset)			
Output Over Voltage Protection	Internal Fuse - Zener crowbar circuit (not user serviceable)			
Input Reverse Polarity Protection	Internal Fuse - Diode bypass circuit (not user serviceable)			
Termination	Screw Terminal - 10-32 UNC with 304 SS Phillips screw			
Conformity	EMC - Australian AS2064 and European EN50081-1 / EN50082-1			
Certification	EMC - Australian C Tick mark and European CE mark			

\*Based on a 50% duty cycle at 10 minute intervals over and above the continuous load rating.

\*\* Based on a surge current load greater than or equal to 10 seconds.

OUTPUT VS LOAD

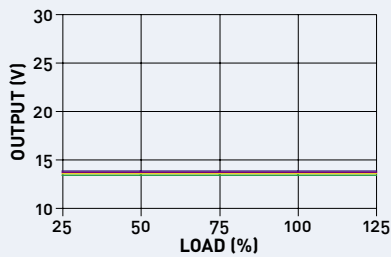

— SVC241215      — SVC241230  
— SVC241220      — SVC241240

EFFICIENCY VS LOAD

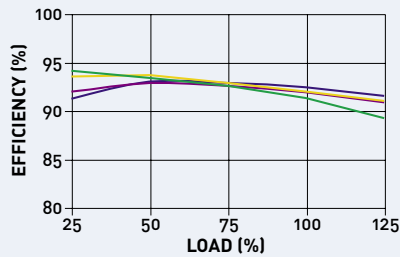

— SVC241215      — SVC241230  
— SVC241220      — SVC241240

OUTPUT AT FULL LOAD VS INPUT

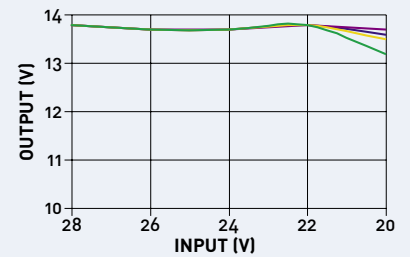

— SVC241215      — SVC241230  
— SVC241220      — SVC241240