

## INSTALLATION AND OPERATING GUIDE

### IMPORTANT

The SBE Battery Equalizer must only be used in accordance with the directives and standards associated with the particular application.

In order to comply with the manufacturer's terms and conditions of warranty the SBE Battery Equalizer must be installed and connected as detailed in the following instructions.

All wiring and connections to the SBE Battery Equalizer must be carried out by a suitably qualified person according to sound electrical installation practices.

Under no circumstances should the SBE Battery Equalizer be modified or adjusted. Opening the case by removing the screws will render the warranty void.

### APPLICATION

An SBE Battery Equalizer can be installed in any 24VDC (two battery) system where a constant 12VDC (nominal) supply is required for operating auxiliary equipment such as lighting, motors, electronics, etc or where there is a need to charge a separate 12VDC battery and the only charging source available is 24VDC.

When installed as an equalizer, the SBE will balance the voltage between two 12VDC batteries where they are connected in a series circuit for a 24VDC system and centre tapped for a 12VDC supply. Under normal circumstances tapping a single battery within a 24 Volt bank for a 12 Volt supply will cause an imbalance between the two batteries. The outcome is reduced battery life due to one bank being over charged whilst the other is under charged. Consider the two batteries in the circuit as the first and second in the series. The first is identified as the 24V + supply and the second as the 24V - ground. The SBE will maintain or 'balance' the second battery when it is used as the 12VDC supply.

In addition the SBE can also be used as a stand alone battery charger to maintain an auxiliary 12VDC battery connected to the 24VDC supply. The SBE is designed to regulate the output voltage to half of the input voltage, nominally 24 VDC ÷2.

The SBE Battery Equalizer is NOT designed to be used as a voltage converter for 24VDC - 12VDC applications. The unit will not operate when connected to 12V equipment as it requires an excitation voltage from a battery connected to the output.

Model	Continuous Rating	Input Fuse Rating
SBE241220	20 Amps maximum @ 30°C (86°F) max.	15 Amps
SBE241230	30 Amps maximum @ 30°C (86°F) max.	20 Amps
SBE241240	40 Amps maximum @ 30°C (86°F) max.	25 Amps

### INSTALLATION

The SBE must be properly mounted in order to comply with environmental considerations and the manufacturer's warranty terms and conditions. As the SBE is ungrounded it can be mounted directly to any metal surface and maintain electrical isolation.

1. The surface must be vertical, hard and flat. Do not install on an upholstered or insulated surface as the rear of the SBE must have clearance from the surface to ensure adequate heat dissipation.
2. Ensure the SBE is located in a well ventilated position, free from excessive moisture, dust, vibration and heat. A minimum of 50mm clearance should be allowed to other equipment at the top and bottom only (see diagram).
3. Ensure that the termination side of the SBE is facing downward and that there is adequate clearance to connect the wiring to the terminals.
4. Fix the SBE with appropriate fasteners ensuring both anchor holes are utilized. Do not overtighten.

### WIRING

In order to ensure safety, good service and long life the SBE Battery Equalizer should be wired and connected according to the following method:

1. Disconnect the 24VDC supply at the source before attempting any connection to the SBE or auxiliary equipment.
2. Install an appropriately rated fuse or circuit breaker (see chart above) as the input protection for the 24VDC supply cable to the SBE.
3. Connect all circuits to the SBE as per the diagram overleaf. Ensure that the correct wire sizes are used for the model installed (consult your wire supplier for appropriate current ratings).
4. Re-connect the input supply at the source and turn on the circuit breaker or switch. The LED Diagnostic indicator on the SBE should now be flashing green intermittently. This indicates the SBE is operational and ready to use. The terminal cover can now be re-fitted. No tools are required - simply click in place by hand. If there is no indication refer to the fault finding section overleaf.

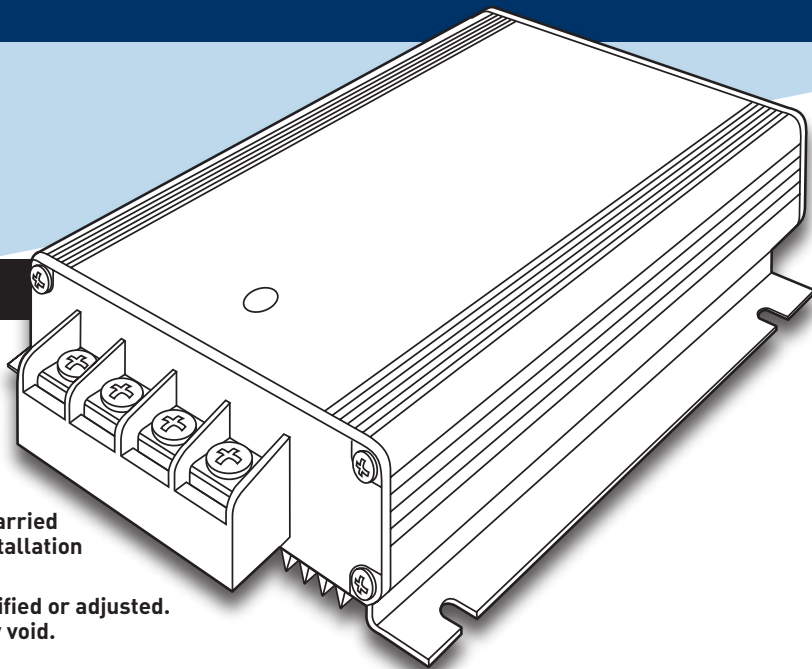

### MOUNTING

**UP**

CLEARANCE  
50mm  
TOP

FIXING

50mm  
BOTTOM  
CLEARANCE

**IMPORTANT: MOUNT ON HARD, FLAT, VERTICAL SURFACE. ENSURE ADEQUATE VENTILATION.**

### WIRING

#### BATTERY EQUALIZING INSTALLATION

TO 12 VDC LOAD

#### AUXILIARY BATTERY CHARGING INSTALLATION

- ① Optional connection to negative [0V] ground. 0V terminals are internally linked
- ② For negative [0V] connection in common ground applications (i.e. vehicle chassis).
- ③ For negative [0V] connection in above ground applications (i.e. vessel hull).

**IMPORTANT: ENSURE ALL WIRING IS ADEQUATELY RATED FOR APPLICABLE LOADS**

## PROTECTION

The SBE Battery Equalizer is protected from a variety of connection and application errors by a range of built in devices. In most situations these errors are revealed by the diagnostic indicator and can be corrected without having caused damage to the SBE. The SBE is protected in the following situations:

- **Low Input Voltage.** If the input voltage falls below the factory preset level the SBE will be disabled. When the input voltage again rises above this setting the output supply will subsequently be restored.
- **Thermal Overload.** In the event the SBE exceeds the factory preset temperature limit the unit will be disabled. When the temperature decreases to the appropriate level the output will automatically be restored.
- **Output Short Circuit.** If the output (auxiliary equipment) is short circuited the SBE will be disabled. When the short circuit is fixed/removed, normal output supply will be restored.
- **Output Overload.** If the output is continually overloaded the SBE will be disabled. When the overload is fixed/removed, normal output supply will be restored.
- **Input Reverse Connection.** If the input terminals are reverse connected the SBE will become inoperable. The input circuit is diode controlled and protected by an internal fuse which is not user serviceable.
- **Transient Input Voltage.** A purpose designed circuit will filter any undesirable, spikes, surges and transient voltages.

## WARRANTY POLICY

interVOLT products are warranted for a period of 24 months against faulty materials and/or workmanship from date of last sale or a maximum of 36 months from the date of manufacture subject to the following terms and conditions:

- The goods must be installed and operated in accordance with the manufacturers recommendations and instructions set out within this guide.
- In the event of a claim the goods are returned to the original point of purchase with a copy of the merchant invoice or the relevant merchant invoice number.
- In the event of a claim any associated expenses including diagnosis, removal, and/or installation of the goods is the responsibility of the client including any freight costs.
- The warranty shall be void where the goods have been used for a purpose for which they are not intended, or altered in any way that is detrimental, or opened or tampered with by an unauthorized party, or damaged by mechanical abuse, or contaminated by water or other substances, or damaged by incorrect application.
- Save and except for the express warranty set out above and to the maximum extent permitted by law, all conditions and warranties which may at any time be implied by the common law, Trade Practices Act, Fair Trading Act or any other State or Federal Act are excluded. To the extent that these cannot be excluded and where the law permits, the manufacturer in respect of any such condition or warranty shall be limited at their option to the repair or the replacement of the goods or the supply of equivalent goods or refunding the cost of the goods.

## DIAGNOSTICS AND FAULT FINDING

Indication	Status	Cause	Remedy
Green – Pulsing	System Normal	N/A	N/A
Green/Red – Pulsing Alternately	Low Input Voltage No Input Voltage	Input voltage has dropped below preset limit (22.5V) Input supply not connected	Check voltage of battery supply Check input supply/connection
Amber – Pulsing	Thermal Overload	Lack of ventilation Continuously exceeding maximum load rating	Check to ensure ventilation to SBE is adequate. Check loads to ensure they do not exceed rating of SBE
Red – Pulsing	Short Circuit or overload No/Low Battery on Output	Short circuit on output (auxiliary equipment) Continuously exceeding maximum load rating Battery is not connected to output or voltage too low	Remove load and check for short circuit Check loads to ensure they do not exceed rating of SBE Connect 12V battery and/or check battery has minimum 8.0V to excite SBE
No Indication	Out Of Service	No input supply Internal fault	Check circuit breaker/switch to ensure circuit is on. Return to authorised service centre